

VLU7 Series 3.3V LVDS VCXO Oscillators

November 2018

- Pletronics' VLU7 Series is a voltage - quartz crystal controlled precision square wave generator with a LVDS output.
- See VPU7 for PECL output
- Tape and Reel or cut tape packaging
- 10.9 MHz to 670 MHz
- Enable/Disable Function on pad 2
- Output frequency is synthesized
- Low Jitter



**Pletronics Inc. certifies this device is in accordance with the
RoHS (2011/65/EC) and WEEE (2002/96/EC) directives.**

Pletronics Inc. guarantees the device does not contain the following:

Cadmium, Hexavalent Chromium, Lead, Mercury, PBB's, PBDE's

Weight of the Device: 0.28 grams

Moisture Sensitivity Level: 1 As defined in J-STD-020D.1

Second Level Interconnect code: e4

Absolute Maximum Ratings:

Parameter	Unit
V _{CC} Supply Voltage	-0.5V to +4.6V
V _i Input Voltage	-0.5V to V _{CC} + 0.5V
V _o Output Voltage	-0.5V to V _{CC} + 0.5V
I _o Output Current	-50mA

Thermal Characteristics

The maximum die or junction temperature is 155°C

The thermal resistance junction to board is 30 to 50°C/Watt depending on the solder pads, ground plane and construction of the PCB.

Part Number:

VLU7029036	EG	000	050	- 312.5M	-XX	
						Packaging code or blank T250 = 250 per Tape and Reel T500 = 500 per Tape and Reel T1K = 1000 per Tape and Reel
						Frequency in MHZ
						Pullability in ppm (Vcontrol) APR 050 = + 50 ppm minimum is standard 075 = + 75 ppm minimum 100 = ± 100 ppm minimum
						Stability in ppm (Stability in ppm * 10) 000 = APR 500 = ± 50 ppm 250 = ± 25 ppm (typical values shown)
						Temperature Range EG = -10 to +70°C LK = -40 to +85°C
						Series Model

Part Marking:

PLE VLU7
FF.FFF M
• YMDXX

Marking Legend:

PLE = Pletronics
 FF.FFF M = Frequency in MHZ
 YMD = Date of Manufacture (year-month-day)
 All other marking is internal factory codes

Codes for Date Code YMD

Code	6	7	8	9	0	Code	A	B	C	D	E	F	G	H	J	K	L	M
Year	2016	2017	2018	2019	2020	Month	JAN	FEB	MAR	APR	MAY	JUN	JUL	AUG	SEP	OCT	NOV	DEC

Code	1	2	3	4	5	6	7	8	9	A	B	C	D	E	F	G
Day	1	2	3	4	5	6	7	8	9	10	11	12	13	14	15	16
Code	H	J	K	L	M	N	P	R	T	U	V	W	X	Y	Z	
Day	17	18	19	20	21	22	23	24	25	26	27	28	29	30	31	

Electrical Specification for 3.30V $\pm 10\%$ over the specified temperature range and the frequency range of 10.9 MHZ to 670 MHZ

Item	Min	Max	Unit	Condition
Pullability, Absolute Pull Range	-50 -75 -100	+50 +75 +100	ppm	APR includes the effects of supply voltages, load changes, aging for 1 year, shock, vibration and temperature. Defined by part number.
Output Waveform	LVDS			
Output High Level	--	1.60	Volts	See load circuit R1 = 50 ohms
Output Low Level	0.90	--	Volts	
Differential Output (V_{OD})	250	450	mVolts	
Output Offset Voltage (V_{OS})	1.125	1.375	Volts	
Differential Output Error (dV_{OS})	--	50	mVolts	
Output Symmetry	47	53	%	Referenced to 50% of amplitude or crossing point
Output T_{RISE} and T_{FALL}	150	230	pS	V_{th} is 20% and 80% of waveform
Jitter	-	0.8	pS RMS	Measured from 12KHz to 20MHz from $F_{nominal}$
	-	3.2		Measured from 10Hz to 20MHz from $F_{nominal}$
Output Short Circuit Current	-	-20	mA	$V_{out} = 0.0V$
Modulation Bandwidth	10	-	KHz	$V_{control} = 1.65V \pm 1.50 V$, -3dB
$V_{control}$ Resistance (Pad 1)	20	-	Kohm	
Voltage vs. Frequency Linearity	-10	+10	%	$V_{control} = 1.65V \pm 1.50 V$
V_{CC} Supply Current	-	90	mA	
Enable/Disable Internal Pull-up	50	-	Kohm	To V_{CC} (equivalent resistance)
V disable	-	0.8	Volts	Referenced to Ground
V enable	2.0	-	Volts	Referenced to Ground
Output leakage $V_{OUT} = V_{CC}$	-20	+20	μA	Pad 1 low, device disabled
	$V_{OUT} = 0V$	-20		
Enable	-	10	nS	Time for output to reach a logic state
Disable time	-	10	nS	Time for output to reach a high Z state
Start up time	-	5	mS	Measured from the time $V_{CC} = 3.0V$
Operating Temperature Range	-10	+70	$^{\circ}C$	Standard Temperature Range
	-40	+85	$^{\circ}C$	Extended Temperature Range "E" Option
Storage Temperature Range	-55	+125	$^{\circ}C$	

Specifications with Pad 2 E/D open circuit or connected to V_{CC}

Typical Phase-Noise Response

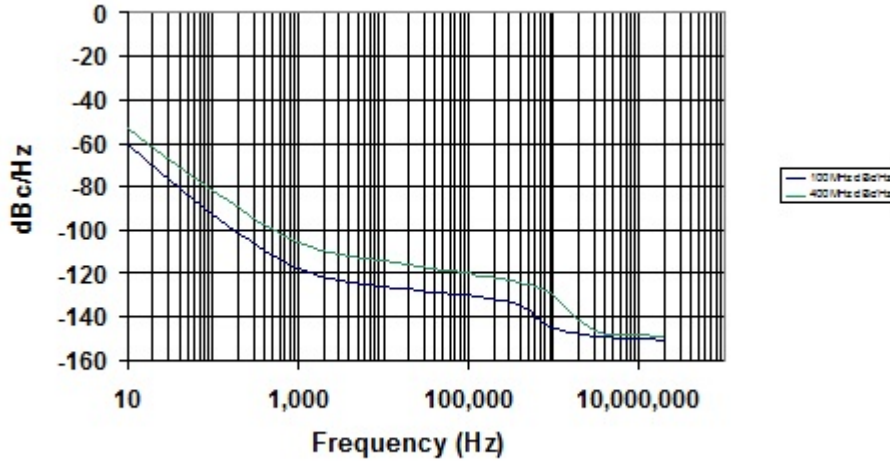

Load Circuit

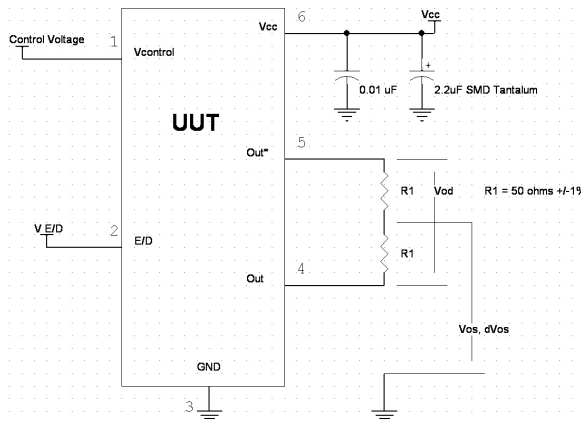

Test Waveform

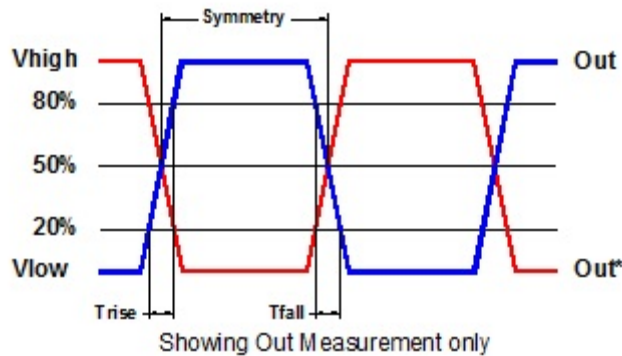

Reliability: Environmental Compliance

Parameter	Condition
Mechanical Shock	MIL-STD-883 Method 2002, Condition B
Vibration	MIL-STD-883 Method 2007, Condition A
Solderability	MIL-STD-883 Method 2003
Thermal Shock	MIL-STD-883 Method 1011, Condition A

ESD Rating

Model	Minimum Voltage	Conditions
Human Body Model	2000	MIL-STD-883 Method 3115
Charged Device Model	1500	JESD 22-C101

Package Labeling

Label is 1" x 2.6" (25.4mm x 66.7mm)
Font is Courier New
Bar code is 39-Full ASCII

Label is 1" x 2.6" (25.4mm x 66.7mm)
Font is Arial

P/N:  VLU7029036EG100050-100.0M Customer P/N:  12345678 Qty:  1000 D/C  MSL: 1 4AN3LGC2-SF2

RoHS Compliant 2nd Lvl Interconnect Category=e4 Max Safe Temp=260C for 10s 2X Max

Mechanical:

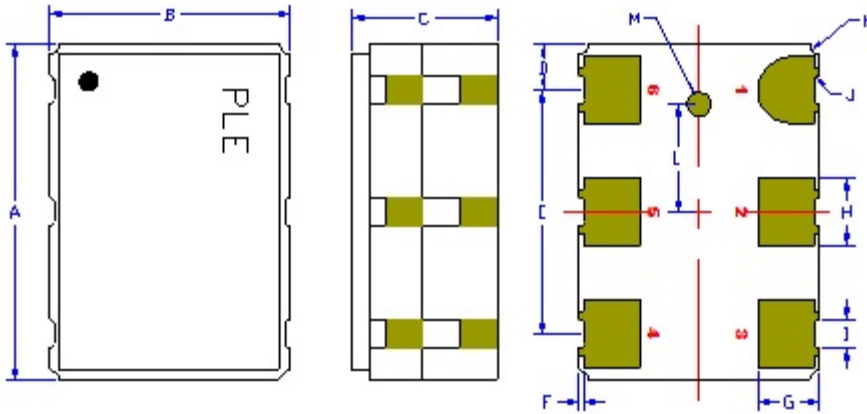

	Inches	mm
A	0.276 \pm 0.006	7.00 \pm 0.15
B	0.197 \pm 0.006	5.00 \pm 0.15
C	0.117 max	2.97 max
D ¹	0.038	0.96
E ¹	0.200	5.08
F ¹	0.004	0.10
G ¹	0.050	1.27
H ¹	0.055	1.40
I ¹	0.024	0.60
J ¹	0.004r	0.10r
K ¹	0.008r	0.20r
L ¹	0.089	2.25
M ¹	0.010r	0.25r

Contacts (pads):

Gold 11.8 to 39.4 μ mches (0.3 to 1.0 μ m)
over

Nickel 50 to 350 μ mches (1.27 to 8.89 μ m) Not to Scale

Center metallized pad on the base is internally connected, may be open or connected to V_{cc} or to Ground.

¹ Typical dimensions

Do not permit solder to bridge the upper gold contacts on the side.

Pad	Function	Note
1	Vcontrol	Modulates the output frequency
2	Output Enable/Disable	When this pad is not connected the oscillator shall operate. When this pad is <0.80 volts, the output will be inhibited (high impedance state.) Recommend connecting this pad to V_{cc} if the oscillator is to be always on.
3	Ground (GND)	
4	Output	The outputs must be terminated, 100 ohms between the outputs is the ideal termination. Capacitor coupled terminations can be used.
5	Output*	
6	Supply Voltage (V_{cc})	Recommend connecting appropriate power supply bypass capacitors as close as possible.

Reflow Cycle (typical for lead free processing)

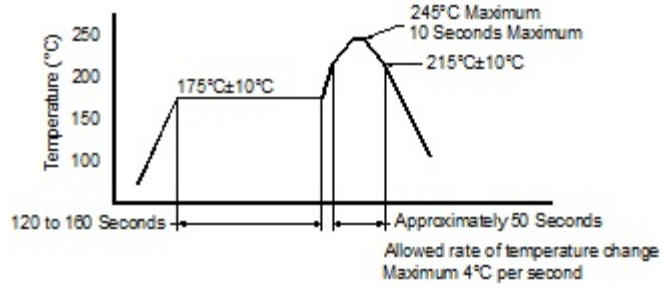

The part may be reflowed 2 times without degradation.

Tape and Reel: available for quantities of 250 to 1000 per reel, cut tape for < 250

Constant Dimensions Table 1								
Tape Size	D0	D1 Min	E1	P0	P2	S1 Min	T Max	T1 Max
8mm	1.5	1.0	1.75	4.0	2.0 ±0.05	0.6	0.6	0.1
12mm		1.5			2.0 ±0.1			
16mm	+0.1 -0.0	1.5	±0.1	±0.1	2.0 ±0.1			
24mm		1.5						

Variable Dimensions Table 2							
Tape Size	B1 Max	E2 Min	F	P1	T2 Max	W Max	Ao, Bo & Ko
16 mm	12.1	14.25	7.5 ± 0.1	8.0 ± 0.1	8.0	16.3	Note 1

Note 1: Embossed cavity to conform to EIA-481-B Dimensions in mm Not to scale

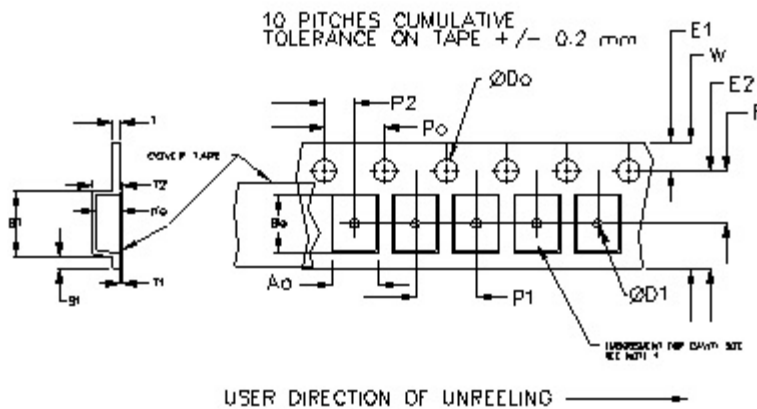
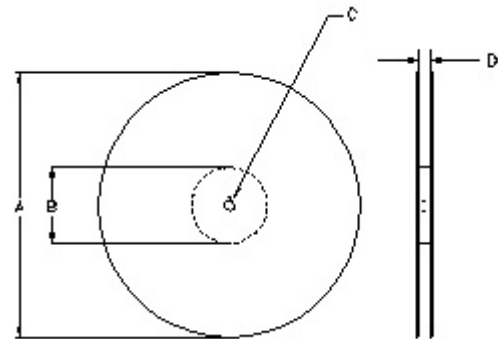

		REEL DIMENSIONS			Tape Width
A	inches	7.0	10.0	13.0	
	mm	177.8	254.0	330.2	
B	inches	2.50	4.00	3.75	
	mm	63.5	101.6	95.3	
C	mm	13.0 +0.5 / -0.2			
D	mm	16.4 +2.0 -0.0	16.4 +2.0 -0.0	16.4 +2.0 -0.0	16.0
	mm	---	---	24.4 +2.0 -0.0	24.0
	mm	---	---	32.4 +2.0 -0.0	32.0

Reel dimensions may vary from the above

IMPORTANT NOTICE

Pletronics Incorporated (PLE) reserves the right to make corrections, improvements, modifications and other changes to this product at anytime. PLE reserves the right to discontinue any product or service without notice. Customers are responsible for obtaining the latest relevant information before placing orders and should verify that such information is current and complete. All products are sold subject to PLE's terms and conditions of sale supplied at the time of order acknowledgment.

PLE warrants performance of this product to the specifications applicable at the time of sale in accordance with PLE's limited warranty. Testing and other quality control techniques are used to the extent PLE deems necessary to support this warranty. Except where mandated by specific contractual documents, testing of all parameters of each product is not necessarily performed.

PLE assumes no liability for application assistance or customer product design. Customers are responsible for their products and applications using PLE components. To minimize the risks associated with the customer products and applications, customers should provide adequate design and operating safeguards.

PLE products are not designed, intended, authorized or warranted to be suitable for use in life support applications, weapons, weapon systems or space applications, devices or systems or other critical applications that may involve potential risks of death, personal injury or severe property or environmental damage. Inclusion of PLE products in such applications is understood to be fully at the risk of the customer. Use of PLE products in such applications requires the written approval of an appropriate PLE officer. Questions concerning potential risk applications should be directed to PLE.

PLE does not warrant or represent that any license, either express or implied, is granted under any PLE patent right, copyright, artwork or other intellectual property right relating to any combination, machine or process which PLE product or services are used. Information published by PLE regarding third-party products or services does not constitute a license from PLE to use such products or services or a warranty or endorsement thereof. Use of such information may require a license from a third party under the patents or other intellectual property of the third party, or a license from PLE under the patents or other intellectual property of PLE.

Reproduction of information in PLE data sheets or web site is permissible only if the reproduction is without alteration and is accompanied by associated warranties, conditions, limitations and notices. Reproduction of this information with alteration is an unfair and deceptive business practice. PLE is not responsible or liable for such altered documents.

Resale of PLE products or services with statements different from or beyond the parameters stated by PLE for that product or service voids all express and implied warranties for the associated PLE product or service and is an unfair or deceptive business practice. PLE is not responsible for any such statements.

Contacting Pletronics Inc.

Pletronics Inc.
19013 36th Ave. West
Lynnwood, WA 98036-5761 USA

Tel: 425-776-1880
Fax: 425-776-2760
E-mail: ple-sales@pletronics.com
URL: www.pletronics.com

Copyright © 2018 Pletronics Inc.