



# PLETRONICS SM33J Series 3.3V CMOS Clock Oscillator



SM33JV  
2.5 x 2.0 x 0.81 mm  
LCC Ceramic Package

## Features

- Pletronics' SM33J Series is a quartz crystal controlled precision square wave oscillator
- CMOS Output (will interface with TTL devices)
- Enable/Disable Function includes low standby power
- Low Jitter
- 3.3V nominal Supply Voltage
- 1.25-125 MHz Frequency Range

## Applications

Driving A/Ds, D/As, FPGAs  
Digital Video  
Ethernet, GbE  
Medical  
Storage Area Networking  
COTS  
Broad Band Access  
SONET/ SDH/ DWDM  
Base Stations/ Picocell  
Test & Measurement

## Electrical Characteristics

Parameter	Min	Typ	Max	Unit	Condition	
Frequency Range <sup>2</sup>	1.25	-	125	MHz	Consult factory for other options	
Frequency Stability <sup>2</sup> ± 20 = <b>20*</b> , ± 25 = <b>44</b> , ± 50 = <b>45</b>	±20	-	±50	ppm	Includes supply voltage change, load change, aging for 1 year at 25°C ± 2°C, shock, vibration and temperatures. *limited frequencies, see page 3	
Operating Temperature Range <sup>2</sup>	-10 -20 -40 -40	- - - -	+70 +70 +85 +105	°C	Standard range Extended range <b>C</b> option Extended range <b>E</b> option Extended range <b>G</b> option	
Supply Voltage <sup>1,2</sup> (V <sub>CC</sub> )	2.97	3.3	3.63	Volts	3.3V ± 10%	
Output Waveform	CMOS					
Duty Cycle	45	-	55	%	@0.5V <sub>CC</sub> level	
Output V <sub>HIGH</sub> (VOH)	V <sub>CC</sub> - 0.4	-	-	V		
Output V <sub>LOW</sub> (VOL)	-	-	0.4	V		
Output T <sub>RISE</sub> and T <sub>FALL</sub>	-	1	5	ns		C <sub>LOAD</sub> = 15 pF 10% to 90% of V <sub>CC</sub> See Load Circuit
Startup Time	-	-	10	ms	Time for output to reach specified frequency	
V <sub>DISABLE</sub> (VIL)	-	-	30	%	Of V <sub>CC</sub> applied to Pad 1	
V <sub>ENABLE</sub> (VIH)	70	-				
Enable Time	-	-	100	ns	Time for output to reach a logic state	
Disable Time	-	-	200	ns	Time for output to reach a high Z state	
Enable/Disable Internal Pull-up	30	70	150	Kohm	To V <sub>CC</sub> , Pad 1 open or ≥0.7V <sub>CC</sub>	
Standby Current (Pad 1 low)	-	-	10 20	μA	-40 to +85°C -40 to +105°C	Output disabled to tristate
Output Leakage Current	- -10	-	+10 -	μA	Out = V <sub>CC</sub> Out = Gnd	Pad 1 low
Phase Noise	10 Hz 100 Hz 1 kHz 10 kHz 100 kHz 1 MHz 10 MHz	-	-63 -94 -125 -144 -151 -155 -158	-	dBc/Hz	25°C ± 2°C at 100 MHz
Storage Temperature Range	-55	-	+125	°C		

Notes: Specifications with Pad 1 E/D open circuit

<sup>1</sup> Place an appropriate power supply bypass capacitor next to device for correct operation

<sup>2</sup> Specified by part number



# PLETRONICS SM33J Series 3.3V CMOS Clock Oscillator

## Electrical Characteristics

Parameter	Min	Typ	Max	Unit	Condition
Supply Current $I_{cc}$		0.9	1.8		3 MHz
		1.4	2.8		5 MHz
	-	1.5	3.0		10 MHz
	-	1.7	3.4		20 MHz
	-	3.5	7.0	mA	50 MHz
	-	4.0	8.0		65 MHz
		4.5	9.0		85 MHz
		5.5	10.5		100 MHz

Specifications with Pad 1 E/D circuit open



# PLETRONICS SM33J Series 3.3V CMOS Clock Oscillator

## Part Number

Series Model	Frequency Stability		Operating Temperature Range	Supply Voltage V <sub>CC</sub>	Frequency in MHz	Optional T&R Packaging code
SM33	45	J	E	V	- 75.0M	-XX
	45 = ± 50 ppm (STD) 44 = ± 25 ppm 20* = ± 20 ppm		Blank = -10 to +70°C (STD) C = -20 to +70°C E = -40 to +85°C G = -40 to +105°C**	V = 3.3V ± 10%	1.25 - 125 MHz	T250 = 250 per Reel T500 = 500 per Reel T3K = 3000 per Reel (Std)

\* Contact PLE sales for limited frequencies. Full frequency range available which excludes aging.  
\*\* ±50ppm

## Device Marking

<b>PFF.FF</b> • YMDxxx
---------------------------

P = Pletronics  
FF.FF = Frequency in MHz  
YMD = Date Code, All other marking is internal code

Note: Specifications such as frequency stability, supply voltage and operating temperature range, etc. are not identified from marking. External packaging labels and packing list will correctly identify the ordered Pletronics part number.

Codes for Date Code YMD (Year Month Day)

Code	4	5	6	7	8	Code	A	B	C	D	E	F	G	H	J	K	L	M
Year	2024	2025	2026	2027	2028	Month	JAN	FEB	MAR	APR	MAY	JUN	JUL	AUG	SEP	OCT	NOV	DEC

Code	1	2	3	4	5	6	7	8	9	A	B	C	D	E	F	G
Day	1	2	3	4	5	6	7	8	9	10	11	12	13	14	15	16
Code	H	J	K	L	M	N	P	R	T	U	V	W	X	Y	Z	
Day	17	18	19	20	21	22	23	24	25	26	27	28	29	30	31	

## Package Labeling

P/N Label is 1" x 2.6" (25.4mm x 66.7mm)  
Font is Courier New  
Bar code is 39-Full ASCII

RoHS Label is 1" x 2.6" (25.4mm x 66.7mm)  
Font is Arial

<b>P/N:</b> PLE Part Number <b>Customer P/N:</b> 12345678 <b>Qty:</b> 3000 <b>D/C</b> 2A1 MSL: 1
---

<b>RoHS Compliant</b> 2nd Lvl Interconnect Category=e4 Max Safe Temp=260C for 10s 2X Max
---

Pletronics Inc. certifies this device is in accordance with the RoHS and REACH directives.

Pletronics Inc. guarantees the device does not contain the following: Cadmium, Hexavalent Chromium, Lead, Mercury, PBB's, PBDE's  
 Weight of the Device: 0.015 grams  
 Moisture Sensitivity Level: 1 As defined in J-STD-020D  
 Second Level Interconnect code: e4

## Mechanical Dimensions

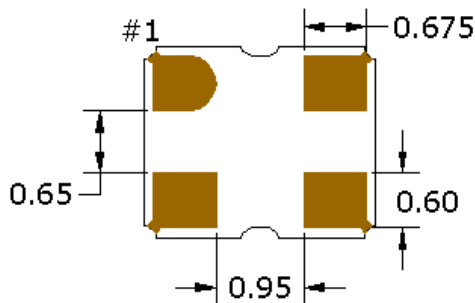
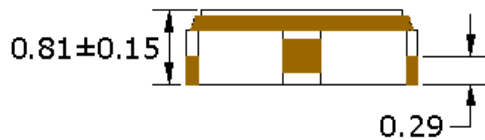
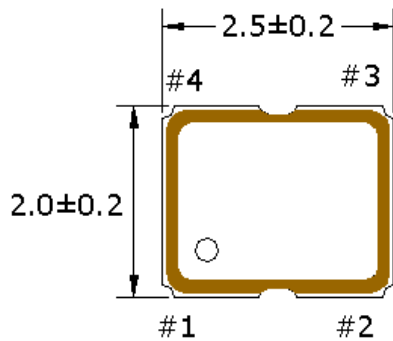

Shape of pad 1 may differ  
Dimensions in mm

## Pad Connections

Pad	Function
1	Enable/Disable
2	Ground
3	Output
4	Vcc

ENABLE/DISABLE	
Pad 1	Output
V <sub>IH</sub> /Open	Active
V <sub>IL</sub> /Gnd	Disabled/Tristate

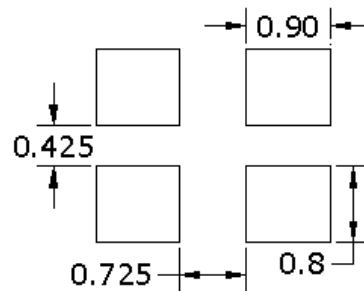

### Pad Layout

Disclaimer: Recommended layout shown. Adjust layout as needed for individual process requirements.

**Contacts (pads): Gold (0.3 to 1.0 μm) over Nickel (1.27 to 8.89 μm)**

For Optimum Jitter Performance, Pletronics recommends:

- A ground plane under the device
- Do not route large transient signals (both current and voltage) under the device
- Do not place near a large magnetic field such as a high frequency switching power supply
- Do not place near piezoelectric buzzers or mechanical fans

## Electrical Test / Load Circuit

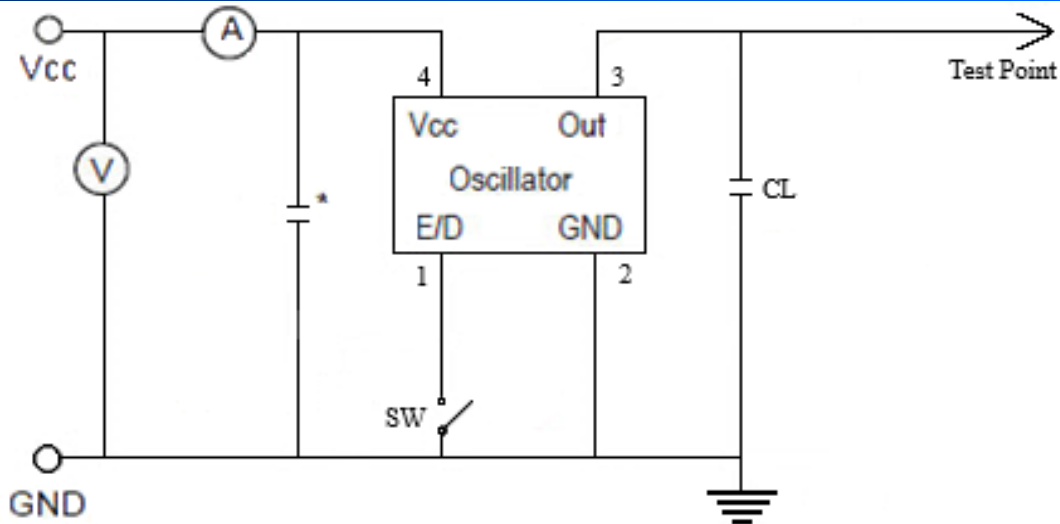

Notes:

CL: 15pF Includes the input capacitance of oscilloscope  
 \* 0.01 $\mu$ F external by-pass filter is recommended

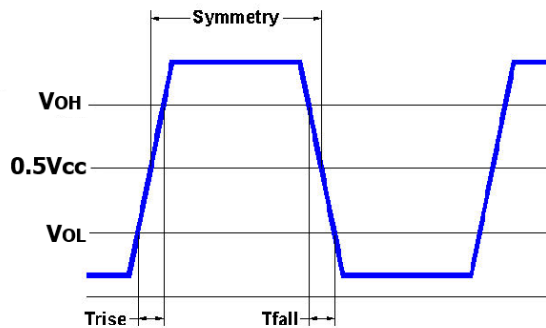

## Environmental / ESD Ratings

Reliability: Environmental

Parameter	Condition
Mechanical Shock	MIL-STD-883, Method 2002, Condition B
Vibration	MIL-STD-883, Method 2007, Condition A
Solderability	IPC J-STD-002
Thermal Cycle	MIL-STD-883 Method 1010, Condition B

ESD Rating

Model	Min. Voltage	Condition
Human Body Model	2000V	JESD22-A114
Machine Model	200V	JESD22-A115

Absolute Maximum Ratings

Parameter	Unit
V <sub>CC</sub> Supply Voltage	-0.3V to +4.0V
V <sub>i</sub> Input Voltage	-0.3V to V <sub>CC</sub> + 0.3V
V <sub>o</sub> Output Voltage	-0.3V to V <sub>CC</sub> + 0.3V

### Thermal Characteristics:

The maximum die or junction temperature is 150°C

## Reflow Cycle

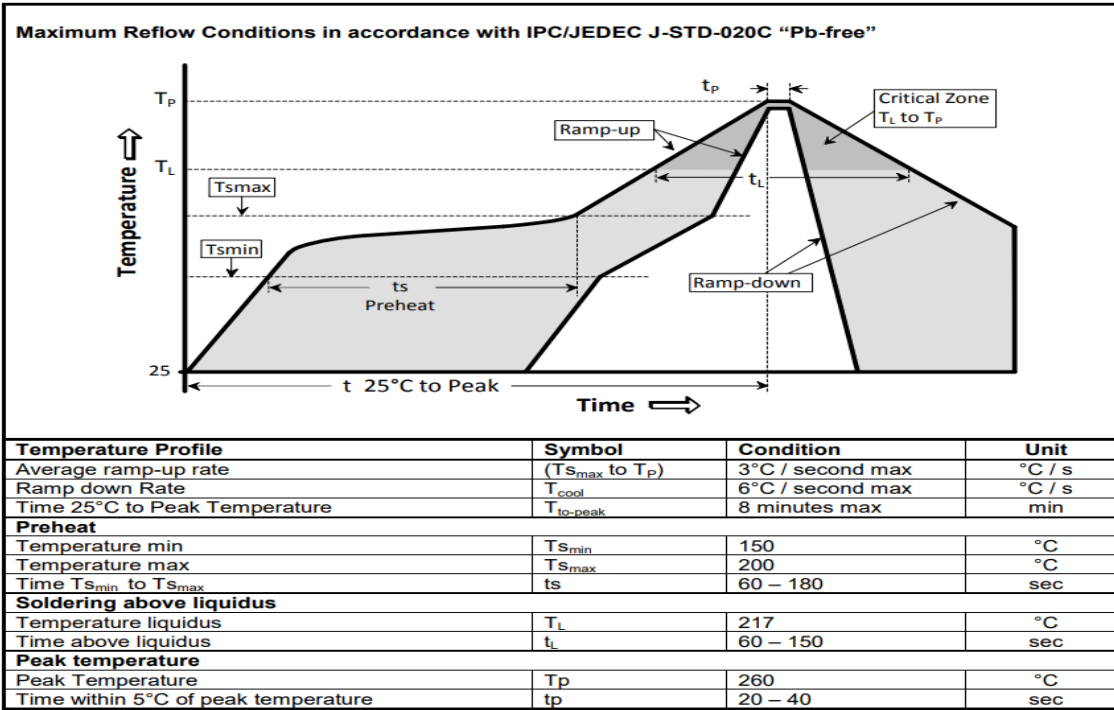

The part may be reflowed 2 times without degradation (typical for lead free processing).

## Tape and Reel

Tape and Reel available for quantities of 250 to 3000 per reel, cut tape for < 250. 8mm tape, 4mm pitch.

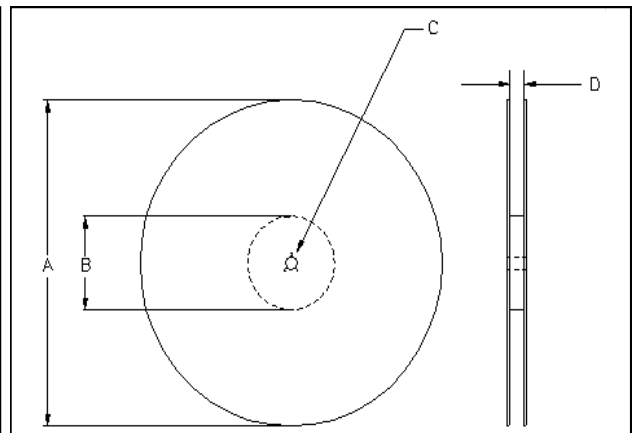
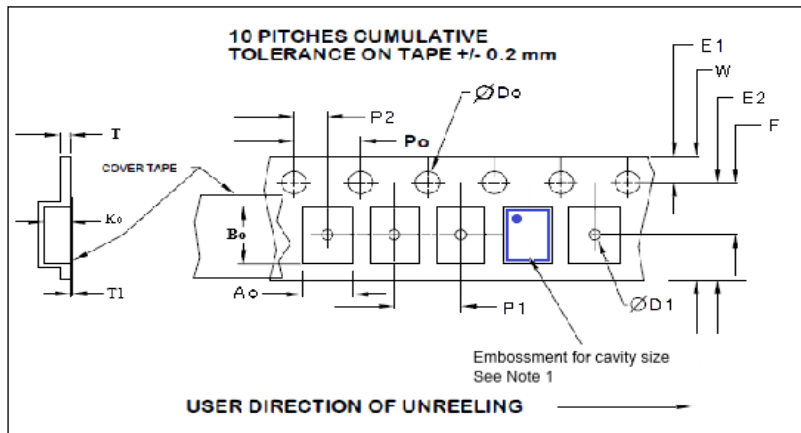

Tape Size	E2 typ	F	P1	W max	Ao	Bo	Ko
8mm	6.25	3.5 ±0.05	4.0 ±0.1	8.2	2.25 ± 0.1	2.75 ± 0.1	1.15 ± 0.1

Reel Size	A		B		C	D
	Inches	mm	Inches	mm	mm	mm
7	7.0	180	2.50	60	13.0 +0.5 -0.2	Tape size +0.4 +2.0 -0.0

Dimensions in mm Drawing Not to scale  
Note 1: Embossed cavity to conform to EIA-481-B

Tape Size	Do	D1 min	E1	Po	P2	T max	T1 max
8mm	1.5 +0.1 -0.0	1.0	1.75 ±0.1	4.0 ±0.1	2.0 ±0.05	0.3	0.1



# PLETRONICS SM33J Series 3.3V CMOS Clock Oscillator

## Important Notice

Pletronics Incorporated (PLE) reserves the right to make corrections, improvements, modifications and other changes to this product at anytime. PLE reserves the right to discontinue any product or service without notice. Customers are responsible for obtaining the latest relevant information before placing orders and should verify that such information is current and complete. All products are sold subject to PLE's terms and conditions of sale supplied at the time of order acknowledgment.

PLE warrants performance of this product to the specifications applicable at the time of sale in accordance with PLE's limited warranty. Testing and other quality control techniques are used to the extent PLE deems necessary to support this warranty. Except where mandated by specific contractual documents, testing of all parameters of each product is not necessarily performed.

PLE assumes no liability for application assistance or customer product design. Customers are responsible for their products and applications using PLE components. To minimize the risks associated with the customer products and applications, customers should provide adequate design and operating safeguards.

PLE products are not designed, intended, authorized or warranted to be suitable for use in life support applications, weapons, weapon systems or space applications, devices or systems or other critical applications that may involve potential risks of death, personal injury or severe property or environmental damage. Inclusion of PLE products in such applications is understood to be fully at the risk of the customer. Use of PLE products in such applications requires the written approval of an appropriate PLE officer. Questions concerning potential risk applications should be directed to PLE.

PLE does not warrant or represent that any license, either express or implied, is granted under any PLE patent right, copyright, artwork or other intellectual property right relating to any combination, machine or process which PLE product or services are used. Information published by PLE regarding third-party products or services does not constitute a license from PLE to use such products or services or a warranty or endorsement thereof. Use of such information may require a license from a third party under the patents or other intellectual property of the third party, or a license from PLE under the patents or other intellectual property of PLE.

Reproduction of information in PLE data sheets or web site is permissible only if the reproduction is without alteration and is accompanied by associated warranties, conditions, limitations and notices. Reproduction of this information with alteration is an unfair and deceptive business practice. PLE is not responsible or liable for such altered documents.

Resale of PLE products or services with statements different from or beyond the parameters stated by PLE for that product or service voids all express and implied warranties for the associated PLE product or service and is an unfair or deceptive business practice. PLE is not responsible for any such statements.

### Contacting Pletronics Inc.

Pletronics, Inc.  
19013 36th Ave. West  
Lynnwood, WA 98036-5761  
U.S.A.

Tel: 425.776.1880  
Fax: 425.776.2760  
email: [ple-sales@pletronics.com](mailto:ple-sales@pletronics.com)  
URL: [www.pletronics.com](http://www.pletronics.com)