



# PLETRONICS PE44J Series 2.5V PECL Clock Oscillator



PE44JV  
3.2 x 2.5 x 0.9 mm  
LCC Ceramic Package

## Features

- Quartz crystal controlled Precision Square Wave Oscillator
- PECL Differential Output
- Enable/Disable Function on pad 1
- Low Jitter
- 2.5V nominal Supply Voltage
- 25 - 320 MHz Frequency Range

## Applications

Driving A/Ds, D/As, FPGAs  
Fibre Channel  
Ethernet, GbE, SynchE  
Medical  
Storage Area Networking  
COTS  
Telecom  
PON

## Electrical Characteristics

Parameter	Min	Typ	Max	Unit	Condition
Frequency Range <sup>2</sup> (Fo)	25	-	320	MHz	
Frequency Stability <sup>2</sup> ± 20 = <b>20*</b> , ± 25 = <b>44</b> , ± 50 = <b>45</b>	±20	-	±50	ppm	Includes supply voltage change, load change, aging for 1 year at 25°C ± 2°C, shock, vibration and temperatures. *limited frequencies, see page 2
Operating Temperature Range <sup>2</sup>	-10 -20 -40 -40 -40	-	+70 +70 +85 +105 +125	°C	Standard range Extended range <b>C</b> option Extended range <b>E</b> option Extended range <b>G</b> option Extended range <b>H</b> option
Supply Voltage <sup>1,2</sup> (V <sub>CC</sub> )	2.375	2.5	2.625	V	
Supply Current (I <sub>CC</sub> )	-	-	56 64 68	mA	25 MHz ≤ Fo ≤ 125 MHz 125 MHz < Fo ≤ 200 MHz Fo > 200 MHz
Output Type	LVPECL				
Output High Level (V <sub>OH</sub> )	V <sub>CC</sub> -1.085V	V <sub>CC</sub> -0.95V	V <sub>CC</sub> -0.86V	V	See test circuit
Output Low Level (V <sub>OL</sub> )	V <sub>CC</sub> -1.81V	V <sub>CC</sub> -1.7V	V <sub>CC</sub> -1.62V	V	See test circuit
Output Voltage Amplitude (V <sub>OPP</sub> )	0.4	-	-	V	Single ended measurement, see test circuit
Output T <sub>RISE</sub> and T <sub>FALL</sub>	-	-	0.5	ns	V <sub>th</sub> is 20% and 80% levels of V <sub>OPP</sub> , see test circuit
Start Up Time	-	-	10	ms	Time for output to reach specified frequency
Duty Cycle	45	-	55	%	50% level of V <sub>OPP</sub> , see test circuit
V <sub>DISABLE</sub> (V <sub>IL</sub> )	-	-	0.3V <sub>CC</sub>	V	Referenced to ground
V <sub>ENABLE</sub> (V <sub>IH</sub> )	0.7V <sub>CC</sub>	-			
Enable Time	-	-	10	ms	Time for output to reach specified frequency
Disable Time	-	-	200	ns	Time for output to reach a high Z state
Enable/Disable Internal Pull-up	30	70	150	KΩ	To V <sub>CC</sub> , Pin 1 open or ≥0.7V <sub>CC</sub>
Output Leakage	V <sub>OUT</sub> = V <sub>CC</sub> V <sub>OUT</sub> = 0V	- -10	+10 -	μA	Pad 1 low, device disabled
Standby Current	-	-	30	μA	
rms Phase Jitter	-	0.1	-	ps	12 kHz to 20 MHz offset at 156.25 MHz
Phase Noise	100 Hz 1 kHz 10 kHz 100 kHz 1 MHz	- - -	-64 -98 -127 -142 -152	- -	dBc/Hz 25°C ± 2°C at 156.25 MHz
Storage Temperature Range	-55	-	+125	°C	

Notes: Specifications with Pad 1 E/D open circuit

<sup>1</sup> Place an appropriate power supply bypass capacitor as close as possible to V<sub>CC</sub> for best performance

<sup>2</sup> Specified by part number



# PLETRONICS PE44J Series 2.5V PECL Clock Oscillator

## Part Number

Series Model	Frequency Stability		Operating Temperature Range	Supply Voltage V <sub>CC</sub>	Frequency in MHz	Optional T&R Packaging code
PE44	45	J	E	W	- 100.0M	-XX
	45 = ± 50 ppm (STD) 44 = ± 25 ppm 20* = ± 20 ppm		Blank = -10 to +70°C (STD) C = -20 to +70°C E = -40 to +85°C G = -40 to +105°C (50ppm) H = -40 to +125°C (check sales)	W = 2.5V ± 5%	25 - 320 MHz	T250 = 250 per Reel T500 = 500 per Reel T3K = 3000 per Reel (Std)

\* Contact PLE sales for limited frequencies. Full frequency range available which excludes aging.

## Device Marking

**PFF.FFP**  
• **YMDxxx**

P = Pletronics  
FF.FFP = Frequency in MHz, P for PECL (frequency is 5 characters including decimal)  
YMD = Date Code, All other marking is internal code

Note: Specifications such as frequency stability, supply voltage and operating temperature range, etc. are not identified from marking. External packaging labels and packing list will correctly identify the ordered Pletronics part number.

Codes for Date Code YMD (Year Month Day)

Code	4	5	6	7	8	Code	A	B	C	D	E	F	G	H	J	K	L	M
Year	2024	2025	2026	2027	2028	Month	JAN	FEB	MAR	APR	MAY	JUN	JUL	AUG	SEP	OCT	NOV	DEC

Code	1	2	3	4	5	6	7	8	9	A	B	C	D	E	F	G
Day	1	2	3	4	5	6	7	8	9	10	11	12	13	14	15	16
Code	H	J	K	L	M	N	P	R	T	U	V	W	X	Y	Z	
Day	17	18	19	20	21	22	23	24	25	26	27	28	29	30	31	

## Package Labeling

P/N Label is 1" x 2.6" (25.4mm x 66.7mm)  
Font is Courier New  
Bar code is 39-Full ASCII

RoHS Label is 1" x 2.6" (25.4mm x 66.7mm)  
Font is Arial

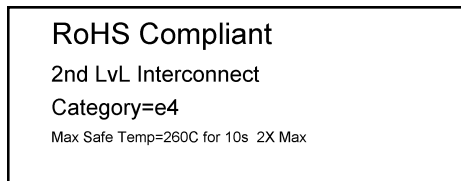
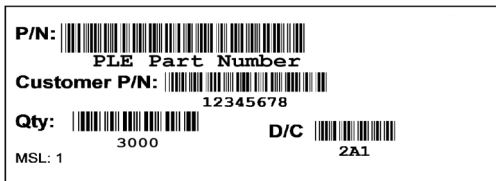

Pletronics Inc. certifies this device is in accordance with the RoHS and REACH directives.

Pletronics Inc. guarantees the device does not contain the following: Cadmium, Hexavalent Chromium, Lead, Mercury, PBB's, PBDE's  
Weight of the Device: 0.028 grams  
Moisture Sensitivity Level: 1 As defined in J-STD-020D  
Second Level Interconnect code: e4



# PLETRONICS PE44J Series 2.5V PECL Clock Oscillator

## Mechanical Dimensions / Pinout

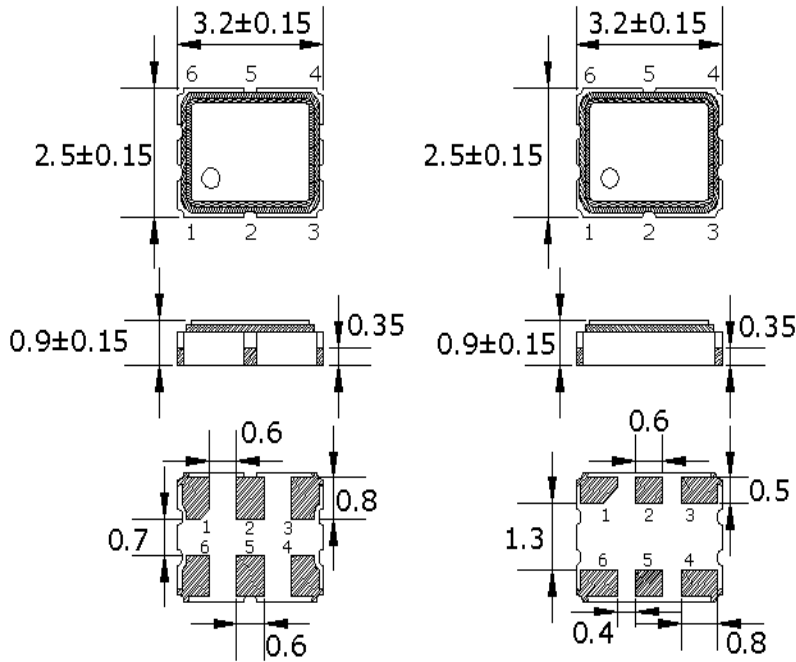

Dimensions in mm

Pin Connections	
PIN#	Function
1	Enable/Disable
2	No connect
3	Ground/Lid
4	Output
5	Output N
6	Vcc

ENABLE/DISABLE	
PIN1	Output
V <sub>H</sub> /Open	Active
V <sub>L</sub> /Gnd	Disabled/Tristate

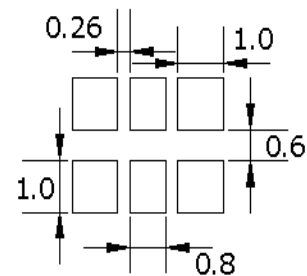

### Pad Layout

Disclaimer: Recommended layout shown. Adjust layout as needed for individual process requirements.

**Contacts (pads): Gold (0.3 to 1.0 μm) over Nickel (1.27 to 8.89 μm)**

For Optimum Jitter Performance, Pletronics recommends:

- A ground plane under the device
- Do not route large transient signals (both current and voltage) under the device
- Do not place near a large magnetic field such as a high frequency switching power supply
- Do not place near piezoelectric buzzers or mechanical fans

## Electrical Test /Load Circuit

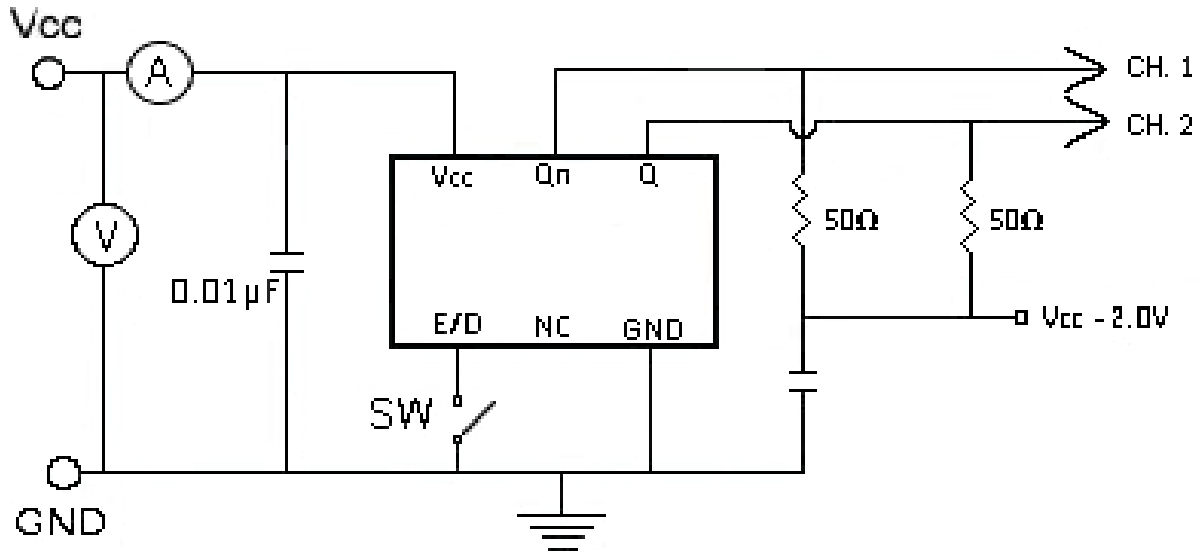

### Test Waveform

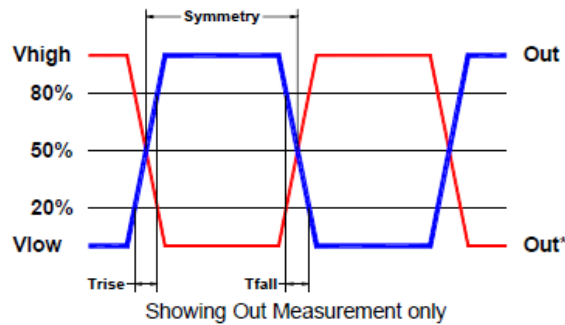

## Environmental / ESD Ratings

Reliability: Environmental

ESD Rating

Parameter	Condition
Mechanical Shock	MIL-STD-883, Method 2002, Condition B
Vibration	MIL-STD-883, Method 2007, Condition A
Solderability	IPC J-STD-002
Thermal Cycle	MIL-STD-883 Method 1010, Condition B

Model	Min. Voltage	Condition
Human Body Model	2000V	JESD22-A114
Machine Model	200V	JESD22-A115

Absolute Maximum Ratings

### Thermal Characteristics:

The maximum die or junction temperature is 150°C

Parameter	Unit
V <sub>CC</sub> Supply Voltage	-0.3V to +4.0V
V <sub>i</sub> Input Voltage	-0.3V to V <sub>CC</sub> + 0.3V
V <sub>o</sub> Output Voltage	-0.3 to V <sub>CC</sub> + 0.3V

## Reflow Cycle

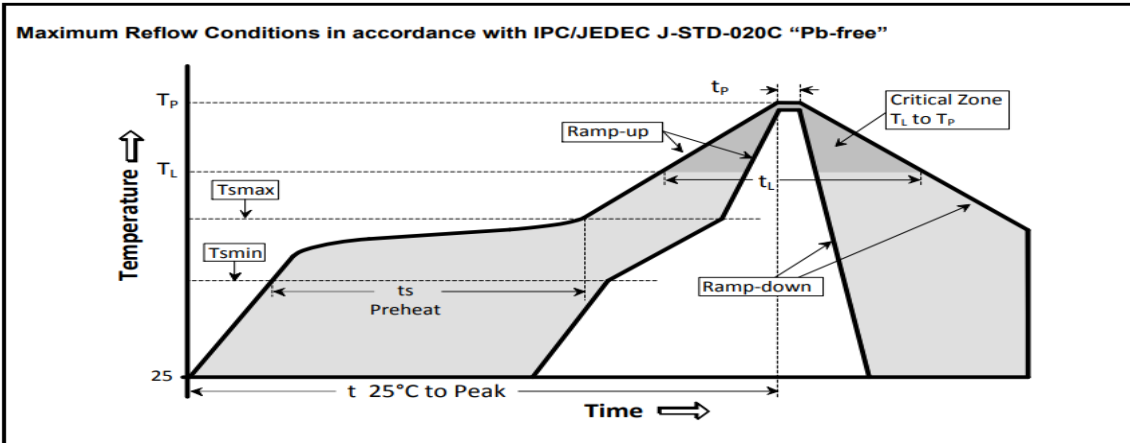

The part may be reflowed 2 times without degradation (typical for lead free processing).

Temperature Profile	Symbol	Condition	Unit
Average ramp-up rate	( $T_{S_{max}}$ to $T_P$ )	3°C / second max	°C / s
Ramp down Rate	$T_{cool}$	6°C / second max	°C / s
Time 25°C to Peak Temperature	$T_{to-peak}$	8 minutes max	min
<b>Preheat</b>			
Temperature min	$T_{S_{min}}$	150	°C
Temperature max	$T_{S_{max}}$	200	°C
Time $T_{S_{min}}$ to $T_{S_{max}}$	$t_s$	60 – 180	sec
<b>Soldering above liquidus</b>			
Temperature liquidus	$T_L$	217	°C
Time above liquidus	$t_L$	60 – 150	sec
<b>Peak temperature</b>			
Peak Temperature	$T_P$	260	°C
Time within 5°C of peak temperature	$t_p$	20 – 40	sec

## Tape and Reel

Tape and Reel available for quantities of 250 to 3000 per reel, cut tape for < 250. 8mm tape, 4mm pitch.

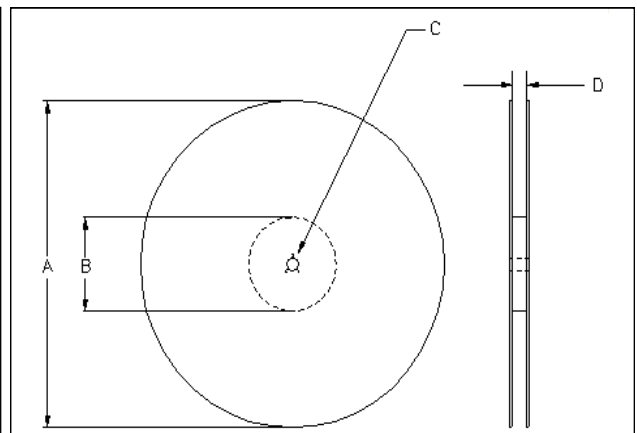
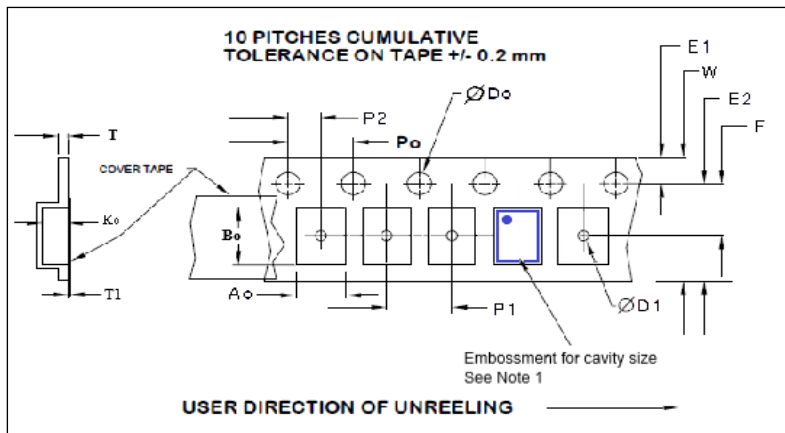

Tape Size	E2 typ	F	P1	W max	Ao	Bo	Ko
8mm	6.25	3.5 ±0.05	4.0 ±0.1	8.2	2.7±0.1	3.4±0.1	1.4±0.1

Reel Size	A		B		C	D
	Inches	mm	Inches	mm	mm	mm
7	7.0	180	2.50	60	13.0	Tape size +0.4
					+0.5 -0.2	+2.0 -0.0

Dimensions in mm Drawing Not to scale  
Note 1: Embossed cavity to conform to EIA- 481-B

Tape Size	Do	D1 typ	E1	Po	P2	T max	T1 max
8mm	1.5 +0.1 -0.0	1.0	1.75 ±0.1	4.0 ±0.1	2.0 ±0.05	0.3	0.1



# PLETRONICS PE44J Series 2.5V PECL Clock Oscillator

## Important Notice

Pletronics Incorporated (PLE) reserves the right to make corrections, improvements, modifications and other changes to this product at anytime. PLE reserves the right to discontinue any product or service without notice. Customers are responsible for obtaining the latest relevant information before placing orders and should verify that such information is current and complete. All products are sold subject to PLE's terms and conditions of sale supplied at the time of order acknowledgment.

PLE warrants performance of this product to the specifications applicable at the time of sale in accordance with PLE's limited warranty. Testing and other quality control techniques are used to the extent PLE deems necessary to support this warranty. Except where mandated by specific contractual documents, testing of all parameters of each product is not necessarily performed.

PLE assumes no liability for application assistance or customer product design. Customers are responsible for their products and applications using PLE components. To minimize the risks associated with the customer products and applications, customers should provide adequate design and operating safeguards.

PLE products are not designed, intended, authorized or warranted to be suitable for use in life support applications, weapons, weapon systems or space applications, devices or systems or other critical applications that may involve potential risks of death, personal injury or severe property or environmental damage. Inclusion of PLE products in such applications is understood to be fully at the risk of the customer. Use of PLE products in such applications requires the written approval of an appropriate PLE officer. Questions concerning potential risk applications should be directed to PLE.

PLE does not warrant or represent that any license, either express or implied, is granted under any PLE patent right, copyright, artwork or other intellectual property right relating to any combination, machine or process which PLE product or services are used. Information published by PLE regarding third-party products or services does not constitute a license from PLE to use such products or services or a warranty or endorsement thereof. Use of such information may require a license from a third party under the patents or other intellectual property of the third party, or a license from PLE under the patents or other intellectual property of PLE.

Reproduction of information in PLE data sheets or web site is permissible only if the reproduction is without alteration and is accompanied by associated warranties, conditions, limitations and notices. Reproduction of this information with alteration is an unfair and deceptive business practice. PLE is not responsible or liable for such altered documents.

Resale of PLE products or services with statements different from or beyond the parameters stated by PLE for that product or service voids all express and implied warranties for the associated PLE product or service and is an unfair or deceptive business practice. PLE is not responsible for any such statements.

### Contacting Pletronics Inc.

Pletronics, Inc.  
19013 36th Ave. West  
Lynnwood, WA 98036-5761  
U.S.A.

Tel: 425.776.1880  
Fax: 425.776.2760  
email: [ple-sales@pletronics.com](mailto:ple-sales@pletronics.com)  
URL: [www.pletronics.com](http://www.pletronics.com)