



PLETRONICS SM8S-AEC Series Automotive RTC Crystal



SM8S-AEC
3.2 x 1.5 x 0.9 mm
Ceramic Package

Features

- Miniature low profile surface mount watch crystal.
- Package is ideal for automated surface mount assembly and reflow practices.
- Tape and Reel Packaging.
- 32.768 kHz

Applications

RTC

Electrical Characteristics

Parameter	Min	Typ	Max	Unit	Condition (Consult factory for other options)
Frequency Range	-	32.768	-	kHz	
Calibration Frequency Tolerance	-	-	±20	ppm	Standard at 25°C ± 3°C. See page 2 for all options
Frequency Stability	-0.027	-0.03	-0.033	ppm/Δ°C ²	
Turnover Temperature	20	25	30	°C	
Operating Temperature Range	-55	-	+125	°C	
Storage Temperature Range	-55	-	+125	°C	
Equivalent Series Resistance (ESR)	-	-	70	kΩ	At 25°C
Drive Level	-	0.1	1	μW	
Q Factor	30000	-	-		
Shunt Capacitance (C0)	-	1.0	-	pF	Pad to Pad Capacitance
Insulation Resistance	500	-	-	MΩ	@100VDC
Aging at 25°C ± 3°C	-	-	±3	ppm	for the first year

Frequency versus Temperature - Typical Performance

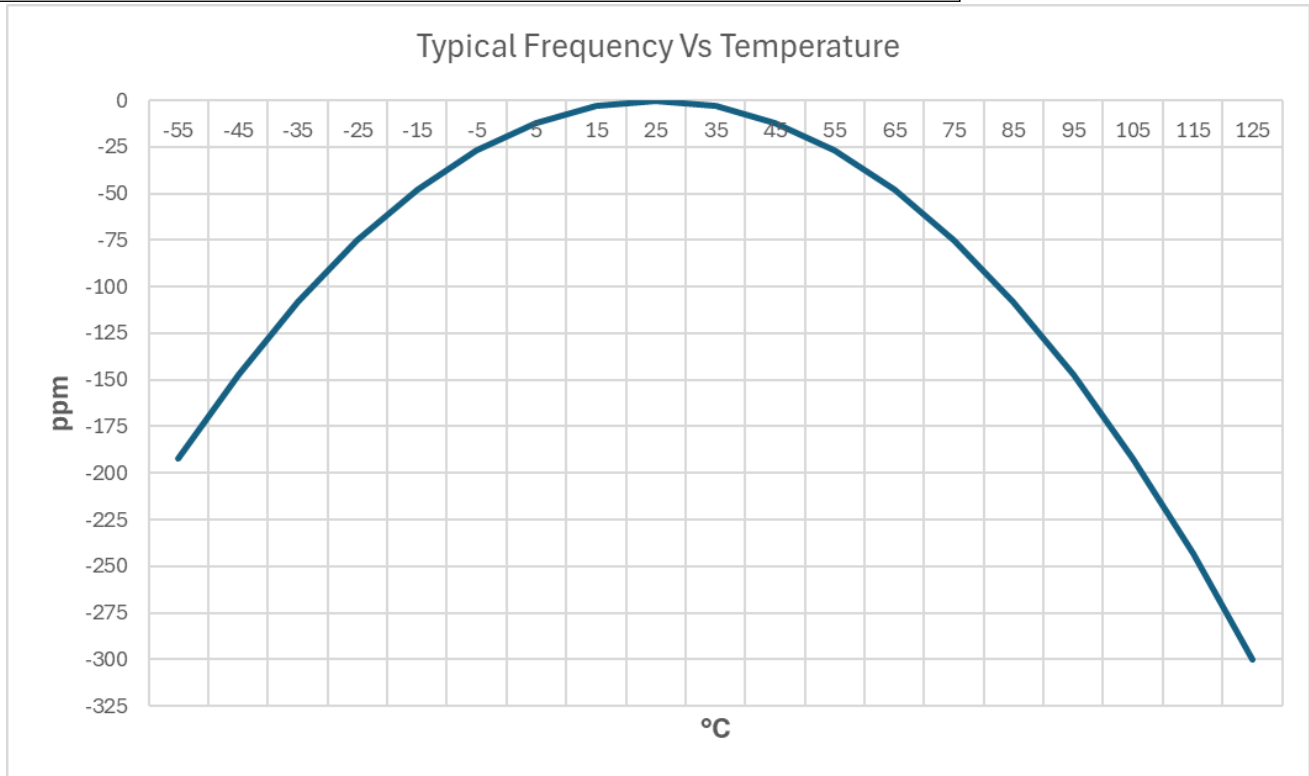



PLETRONICS SM8S-AEC Series Automotive RTC Crystal

Part Numbering

Series Model	Load Capacitance (C _L) in pF	Frequency in kHz	Frequency Calibration Tolerance	Automotive Grade
SM8S	-9	-32.768K	-20	-AEC
	Blank = 12.5 pF 9 = 9 pF 7 = 7 pF 6 = 6 pF		20 = ± 20 ppm Contact PLE for other options	

Device Marking

1. Marking consists of a manufacturing date code
2. Orientation of marking may be mixed on the tape
3. Traceability of part's specification is lost once removed from reel

Package Labeling

P/N Label is 1" x 2.6" (25.4mm x 66.7mm)
Font is Courier New
Bar code is 39-Full ASCII

RoHS Label is 1" x 2.6" (25.4mm x 66.7mm)
Font is Arial

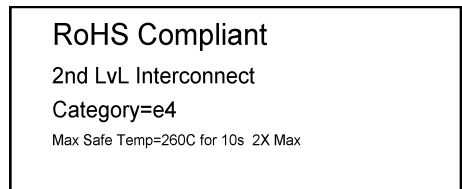
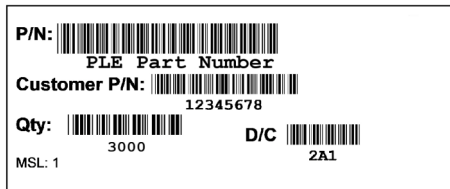

Pletronics Inc. certifies this device is in accordance with the RoHS and REACH directives.

Pletronics Inc. guarantees the device does not contain the following: Cadmium, Hexavalent Chromium, Lead, Mercury, PBB's, PBDE's
Weight of the Device: 0.011 grams
Moisture Sensitivity Level: 1 As defined in J-STD-020D
Second Level Interconnect code: e4

Reliability

Parameter	Condition
Mechanical Shock	JESD22-B104
Vibration	JESD22-B103
Solderability	IPC J-STD-002
Thermal Shock	MIL-STD-883 Method 1011, Condition A



PLETRONICS SM8S-AEC Series Automotive RTC Crystal

Mechanical Dimensions/Solder Pad Layout

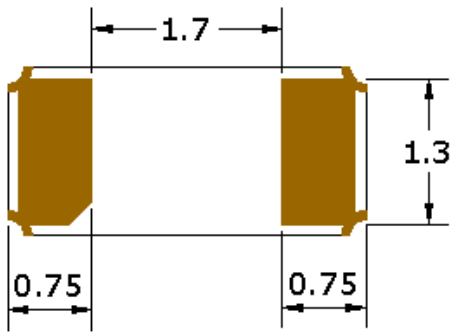
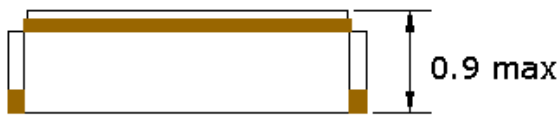
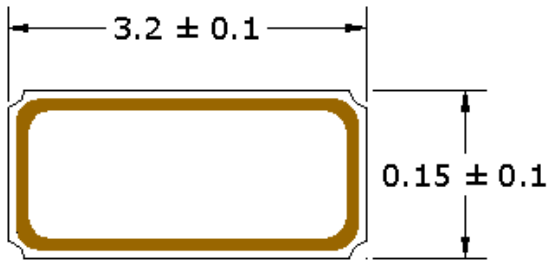

Dimensions in mm

Suggested Solder Pad layout

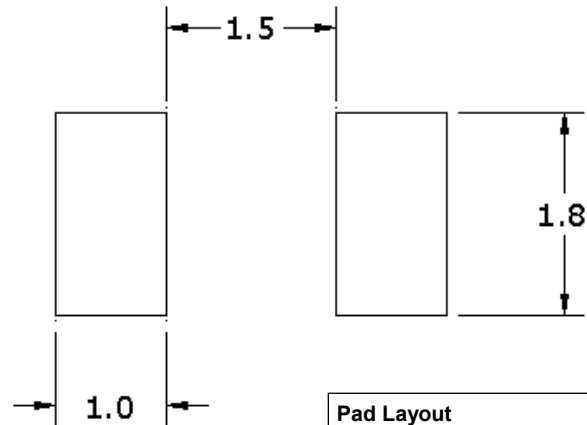

Pad Layout
Disclaimer: Suggested layout shown. Adjust layout as needed for individual process requirements.

Contacts (pads): Gold (0.3 to 1µm) over Nickel (1.27 to 8.89 µm)

For Optimum Performance, Pletronics recommends:

- Trace lengths to the crystal should be kept as short as possible.
- The crystal connections are sensitive to noise.
- These very small crystals have high ESR, the oscillator start-up and operation should take this into consideration.
- No traces to be run under the crystal



PLETRONICS SM8S-AEC Series Automotive RTC Crystal

Reflow Cycle

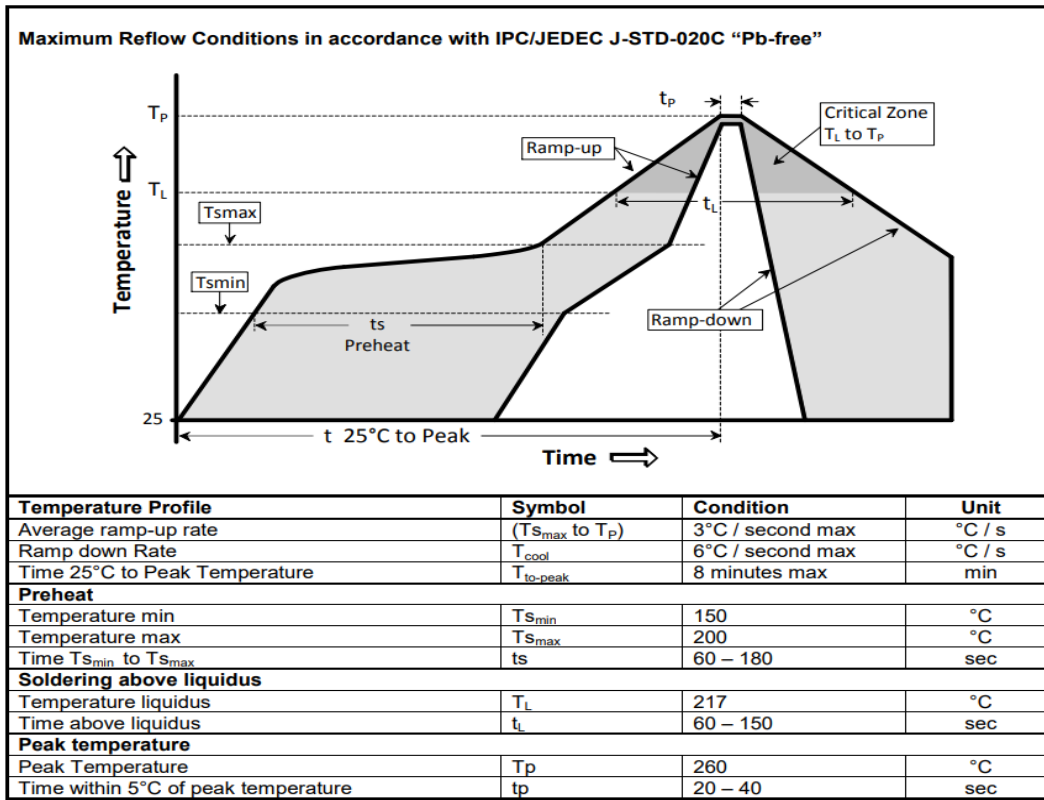

The part may be reflowed 2 times without degradation (typical for lead free processing).

Tape and Reel

Tape and Reel standard quantity = 3000 per reel. 12mm tape, 4mm pitch.

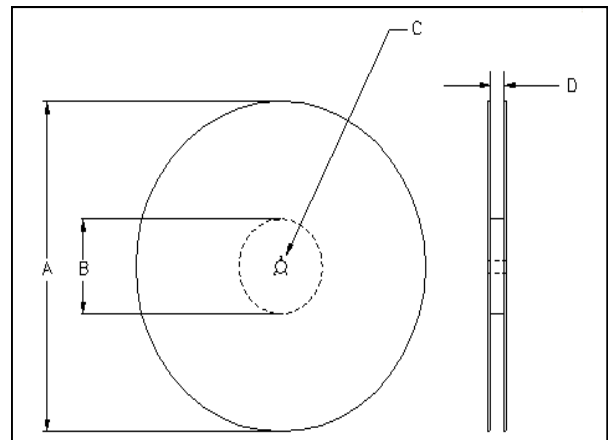
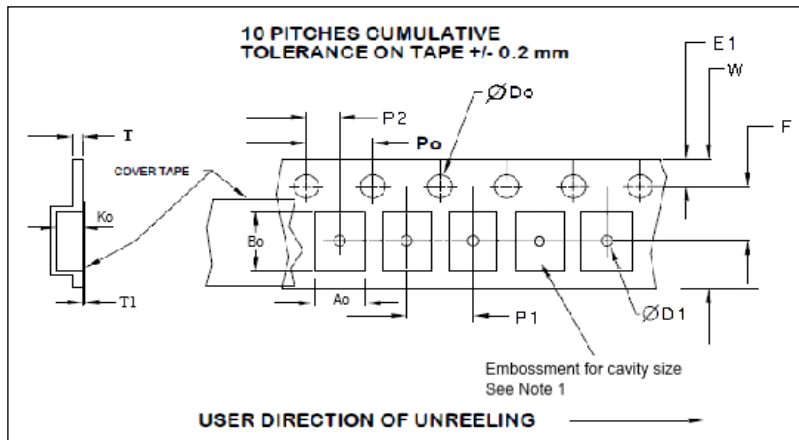

Tape Size	F	P1	W max	Ao	Bo	Ko	Do	D1	E1	Po	P2	T	T1
12mm	5.5 ±0.1	4.0 ±0.1	12.3	1.7	3.4	1.2	1.5 +1.0 -0.0	1.0	1.75 ±0.1	4.0 ±0.1	2.0 ±0.05	0.3	0.1

Dimensions in mm

	A	B	C	D
Reel Size	mm	mm	mm	mm
7	180	60	13.0 +0.5 -0.2	Tape size +0.4 +2.0 -0.0



PLETRONICS **SM8S-AEC Series** Automotive RTC Crystal

Important Notice

Pletronics Incorporated (PLE) reserves the right to make corrections, improvements, modifications and other changes to this product at anytime. PLE reserves the right to discontinue any product or service without notice. Customers are responsible for obtaining the latest relevant information before placing orders and should verify that such information is current and complete. All products are sold subject to PLE's terms and conditions of sale supplied at the time of order acknowledgment.

PLE warrants performance of this product to the specifications applicable at the time of sale in accordance with PLE's limited warranty. Testing and other quality control techniques are used to the extent PLE deems necessary to support this warranty. Except where mandated by specific contractual documents, testing of all parameters of each product is not necessarily performed.

PLE assumes no liability for application assistance or customer product design. Customers are responsible for their products and applications using PLE components. To minimize the risks associated with the customer products and applications, customers should provide adequate design and operating safeguards.

PLE products are not designed, intended, authorized or warranted to be suitable for use in life support applications, weapons, weapon systems and space applications, devices or systems or other critical applications that may involve potential risks of death, personal injury or severe property or environmental damage. Inclusion of PLE products in such applications is understood to be fully at the risk of the customer. Use of PLE products in such applications requires the written approval of an appropriate PLE officer. Questions concerning potential risk applications should be directed to PLE.

PLE does not warrant or represent that any license, either express or implied, is granted under any PLE patent right, copyright, artwork or other intellectual property right relating to any combination, machine or process which PLE product or services are used. Information published by PLE regarding third-party products or services does not constitute a license from PLE to use such products or services or a warranty or endorsement thereof. Use of such information may require a license from a third party under the patents or other intellectual property of the third party, or a license from PLE under the patents or other intellectual property of PLE.

Reproduction of information in PLE data sheets or web site is permissible only if the reproduction is without alteration and is accompanied by associated warranties, conditions, limitations and notices. Reproduction of this information with alteration is an unfair and deceptive business practice. PLE is not responsible or liable for such altered documents.

Resale of PLE products or services with statements different from or beyond the parameters stated by PLE for that product or service voids all express and implied warranties for the associated PLE product or service and is an unfair or deceptive business practice. PLE is not responsible for any such statements.

Contacting Pletronics Inc.

Pletronics, Inc.
19013 36th Ave. West
Lynnwood, WA 98036-5761
U.S.A.

Tel: 425.776.1880
Fax: 425.776.2760
email: ple-sales@pletronics.com
URL: www.pletronics.com