

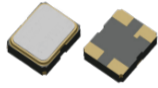

PLETRONICS UCG4 Series TCXO / VCTCXO



UCG4
2.0 x 1.6 x 0.7 mm
LCC Ceramic Package

Features

- Temperature Compensated Crystal Oscillator
- Optional Voltage Control Function
- Clipped Sine Wave Output
- 1.8V to 3.3V nominal Supply Voltage
- 10 - 40 MHz Frequency

Applications

GPS
WiMAX, Wi-Fi, Wi-LAN
Handsets
Broadband Access
Point to point radios
Seismic Exploration
Wireless Communications
Base Stations
Test Equipment

Electrical Characteristics

Parameter	Min	Typ	Max	Unit	Condition (Consult factory for other options)
Frequency Range ²	10	-	40	MHz	Specified by part number
Frequency Stability vs. Temperature ²	± 0.5	-	± 2.5	ppm	Specified by part number $(f_{max} - f_{min}) / 2$
Frequency Initial Calibration	-	-	± 2.0	ppm	For VCTCXO Vcontrol 1.50 volts at 25°C ± 2°C when V _{CC} ≥ 2.5 volts Vcontrol 0.9 volts at 25°C ± 2°C when V _{CC} ≤ 2.4 volts
Operating Temperature Range ²	-40	-	+85	°C	Specified by part number, Consult factory for wider range
Supply Voltage ^{1,2} V _{CC}	1.8	-	3.3	Volts	± 5%, Specified by part number
Supply Current I _{CC}	-	2.0	3.0	mA	Load: 10 KΩ 10 pF, V _{CC} ± 5%
Frequency Stability vs. Supply	-	-	± 0.2	ppm	Load: 10 KΩ 10 pF, V _{CC} ± 5%
Frequency Stability vs. Load	-	-	± 0.2	ppm	Load: 10 KΩ 10 pF ± 5%
Vcontrol Range	0.50 0.30	1.50 0.90	2.50 1.50	Volts	1.50 volts nominal for V _{CC} nominal ≥ 2.5 volts 0.9 volts nominal for V _{CC} nominal ≤ 2.4 volts
Frequency Pullability ²	0	± 8.0	± 12.0	ppm	Specified by part number, Positive Slope
Output Type	Clipped Sine Wave				DC Coupled
Output Level	0.8	-	-	V _{p-p}	Load: 10 KΩ 10 pF ± 10%
Startup Time	-	-	10.0	mS	Within ± 2.0 ppm of final frequency
Long Term Stability (Aging)	-	-	± 1.0	ppm	First year at 25°C ± 2°C
Phase Noise	100 Hz 1 kHz 10 kHz 100 kHz 5 MHz	-	-121 -140 -153 -160 -161	-	dBc/Hz 25°C ± 2°C at 26.0 MHz
Storage Temperature Range	-55	-	+125	°C	

Notes:

¹ Place an appropriate power supply bypass capacitor as close to V_{CC} as possible for best performance.

² Specified by part number



Part Number							
Series Model	V _{CC} Supply Voltage ¹		Operating Temperature		Stability ^{1,2}	Pullability ¹	Frequency
	Lowest	Highest	Lowest	Highest	(ppm)	(ppm)	(MHz)
UCG4	031	035	C	G	015	008	-19.44M
	031 = 3.1 for 3.3 volts nominal 029 = 2.9 for 3.0 volts nominal 027 = 2.7 for 2.8 volts nominal 024 = 2.4 for 2.5 volts nominal 017 = 1.7 for 1.8 volts nominal	035 = 3.5 for 3.3 volts nominal 031 = 3.1 for 3.0 volts nominal 029 = 2.9 for 2.8 volts nominal 026 = 2.6 for 2.5 volts nominal 019 = 1.9 for 1.8 volts nominal	C = 0°C E = -10°C G = -20°C J = -30°C K = -35°C L = -40°C	E = +60°C G = +70°C H = +75°C J = +80°C K = +85°C	005 = ± 0.5 010 = ± 1.0 015 = ± 1.5 020 = ± 2.0 025 = ± 2.5	000 = TCXO 005 = ± 5 008 = ± 8	10 - 40 MHz

¹ Contact Factory for non-standard specifications

² Not all stabilities are available with all operating temperature ranges. Contact Factory for exact combinations available.

Device Marking

Pff.f • YMxxx	P = Pletronics ff.f = Frequency in MHz YM = Date Code (Year Month) See below for YM codes x = All other markings are internal codes
--------------------------------	--

Note: Specifications such as frequency stability, supply voltage and operating temperature range, etc. are not identified from marking. External packaging labels and packing list will correctly identify the ordered Pletronics part number.

Code	4	5	6	7	8	Code	1	2	3	4	5	6	7	8	9	O	N	D
Year	2024	2025	2026	2027	2028	Month	JAN	FEB	MAR	APR	MAY	JUN	JUL	AUG	SEP	OCT	NOV	DEC

Package Labeling

P/N Label is 1" x 2.6" (25.4mm x 66.7mm)
 Font is Courier New
 Bar code is 39-Full ASCII

RoHS Label is 1" x 2.6" (25.4mm x 66.7mm)
 Font is Arial



Pletronics Inc. certifies this device is in accordance with the RoHS and REACH directives.

Pletronics Inc. guarantees the device does not contain the following: Cadmium, Hexavalent Chromium, Lead, Mercury, PBB's, PBDE's
 Weight of the Device: 0.01 grams
 Moisture Sensitivity Level: 1 As defined in J-STD-020D
 Second Level Interconnect code: e4

Pad Connections

Pad	Function
1	TCXO: Gnd VCTCXO: Vc
2	Ground
3	Output
4	Vcc

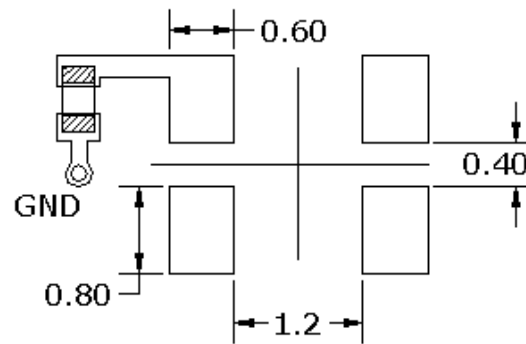
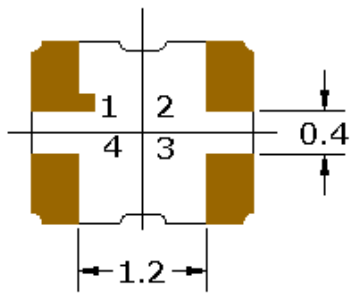
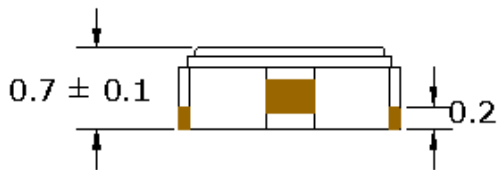
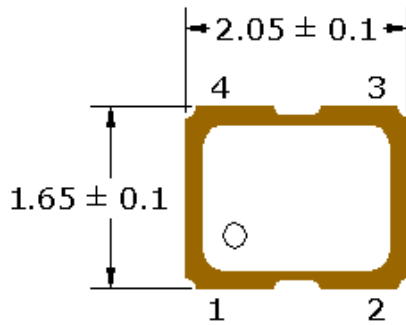

Dimensions in mm

Pad Layout
Disclaimer: Recommended layout shown. Adjust layout as needed for individual process require-

Termination Finish: Gold plating (0.3~1µm) over Nickel plating (1.27~8.87µm)

For Optimum Jitter Performance, Pletronics recommends:

- A ground plane under the device
- Do not route large transient signals (both current and voltage) under the device
- Do not place near a large magnetic field such as a high frequency switching power supply
- Do not place near piezoelectric buzzers or mechanical fans

Electrical Test / Load Circuit

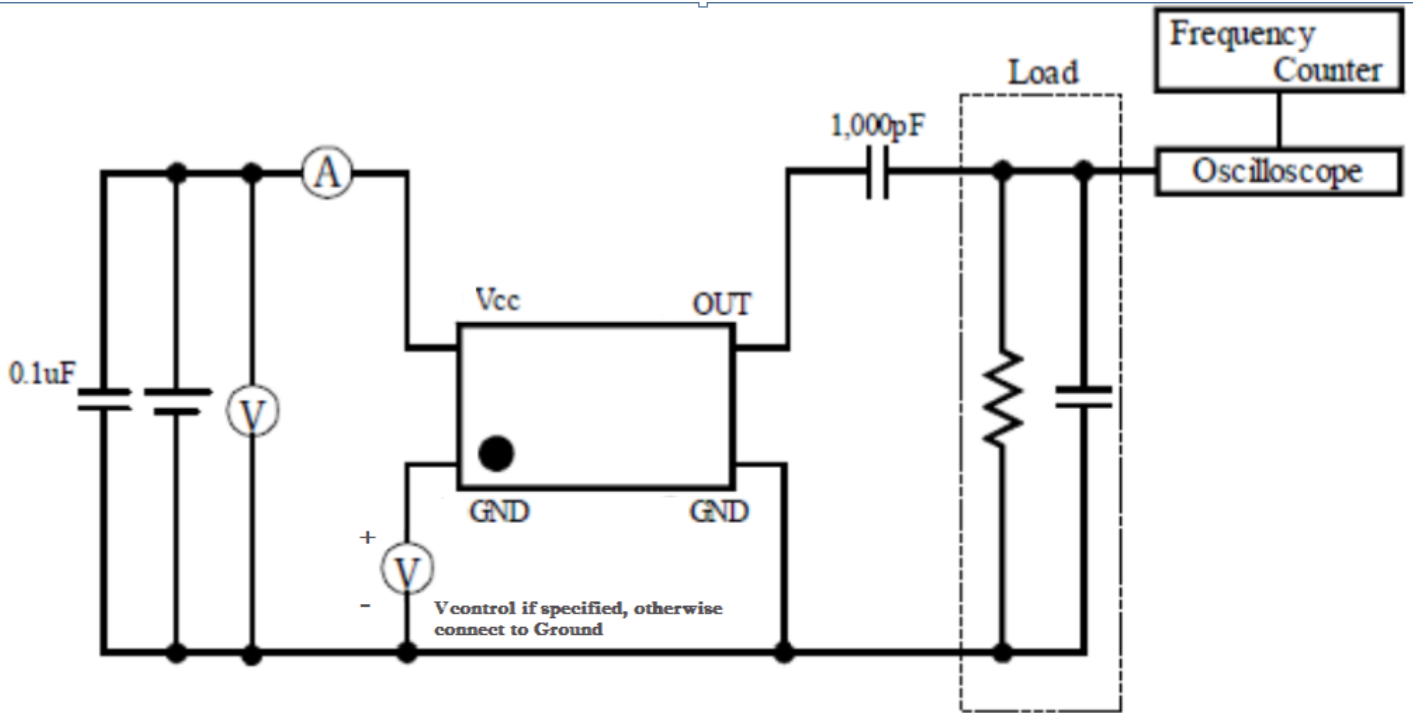

Environmental / ESD Ratings

Reliability: Environmental

Parameter	Condition
Mechanical Shock	MIL-STD-883, Method 2002, Condition B
Vibration	MIL-STD-883, Method 2007, Condition A
Solderability	IPC J-STD-002
Thermal Cycle	MIL-STD-883 Method 1010, Condition B

ESD Rating

Model	Min. Voltage	Condition
Human Body Model	2000V	MIL-STD-883 3015.7
Machine Model	200V	EIAJ ED-4701/304

Absolute Maximum Ratings

Parameter	Unit
V _{CC} Supply Voltage	-0.6V to +4.6V
V _i Input Voltage	-0.6V to V _{CC} + 0.6V
I _o Output Current	-10mA to +10mA

Thermal Characteristics:

The maximum die or junction temperature is 125°C

Reflow Cycle

Maximum Reflow Conditions in accordance with IPC/JEDEC J-STD-020C "Pb-free"

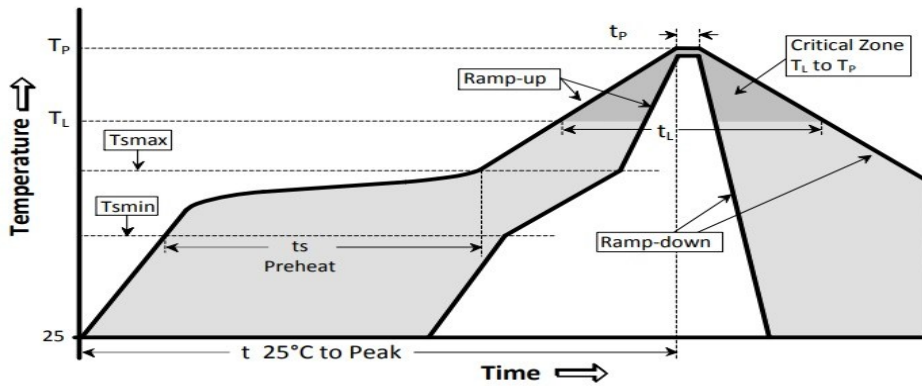

The part may be reflowed 2 times without degradation (typical for lead free processing).

Temperature Profile	Symbol	Condition	Unit
Average ramp-up rate	(T_{Smax} to T_P)	3°C / second max	°C / s
Ramp down Rate	T_{cool}	6°C / second max	°C / s
Time 25°C to Peak Temperature	$T_{to-peak}$	8 minutes max	min
Preheat			
Temperature min	T_{Smin}	150	°C
Temperature max	T_{Smax}	200	°C
Time T_{Smin} to T_{Smax}	t_s	60 – 180	sec
Soldering above liquidus			
Temperature liquidus	T_L	217	°C
Time above liquidus	t_L	60 – 150	sec
Peak temperature			
Peak Temperature	T_P	260	°C
Time within 5°C of peak temperature	t_P	20 – 40	sec

Tape and Reel

Tape and Reel available for quantities of 250 to 3000 per reel, cut tape for < 250. 8mm tape, 4mm pitch. 3K standard quantity

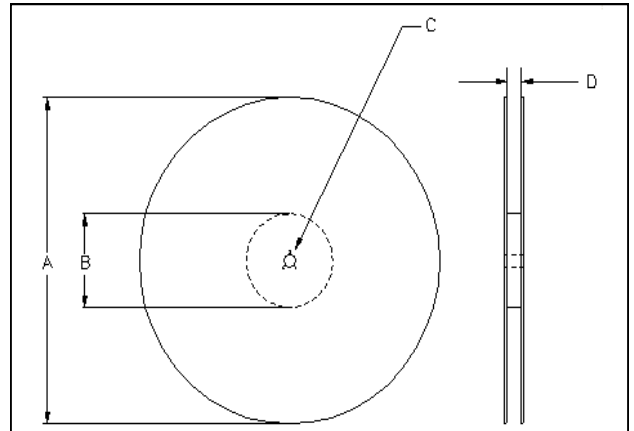
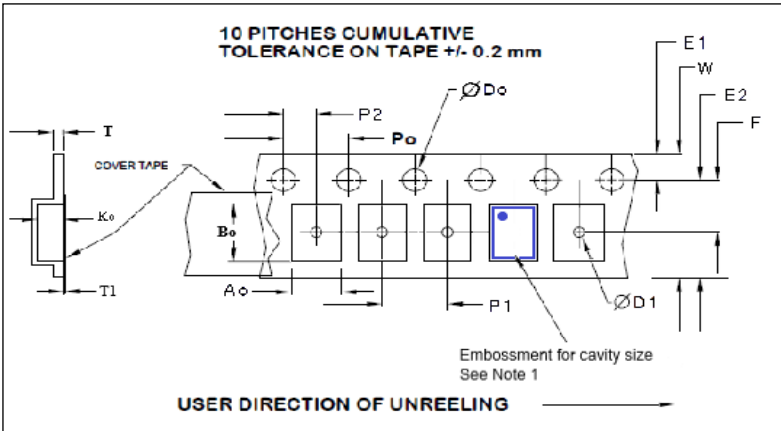

Tape Size	E2 typ	F	P1	W max	Ao	Bo	Ko
8mm	6.25	3.5 ±0.05	4.0 ±0.1	8.2	1.9 ± 0.1	2.3 ± 0.1	0.9 ± 0.1

Dimensions in mm Drawing Not to scale
Note 1: Embossed cavity to conform to EIA-481-B

Tape Size	Do	D1 min	E1	Po	P2	T max	T1 max
8mm	1.5 +0.1 -0.0	1.0	1.75 ±0.1	4.0 ±0.1	2.0 ±0.05	0.3	0.1

Reel Size	A		B		C	D
	Inches	mm	Inches	mm	mm	mm
7	7.0	180	2.50	60	13.0 +0.5 -0.2	Tape size +0.4 +2.0 -0.0



Important Notice

Pletronics Incorporated (PLE) reserves the right to make corrections, improvements, modifications and other changes to this product at anytime. PLE reserves the right to discontinue any product or service without notice. Customers are responsible for obtaining the latest relevant information before placing orders and should verify that such information is current and complete. All products are sold subject to PLE's terms and conditions of sale supplied at the time of order acknowledgment.

PLE warrants performance of this product to the specifications applicable at the time of sale in accordance with PLE's limited warranty. Testing and other quality control techniques are used to the extent PLE deems necessary to support this warranty. Except where mandated by specific contractual documents, testing of all parameters of each product is not necessarily performed.

PLE assumes no liability for application assistance or customer product design. Customers are responsible for their products and applications using PLE components. To minimize the risks associated with the customer products and applications, customers should provide adequate design and operating safeguards.

PLE products are not designed, intended, authorized or warranted to be suitable for use in life support applications, weapons, weapon systems or space applications, devices or systems or other critical applications that may involve potential risks of death, personal injury or severe property or environmental damage. Inclusion of PLE products in such applications is understood to be fully at the risk of the customer. Use of PLE products in such applications requires the written approval of an appropriate PLE officer. Questions concerning potential risk applications should be directed to PLE.

PLE does not warrant or represent that any license, either express or implied, is granted under any PLE patent right, copyright, artwork or other intellectual property right relating to any combination, machine or process which PLE product or services are used. Information published by PLE regarding third-party products or services does not constitute a license from PLE to use such products or services or a warranty or endorsement thereof. Use of such information may require a license from a third party under the patents or other intellectual property of the third party, or a license from PLE under the patents or other intellectual property of PLE.

Reproduction of information in PLE data sheets or web site is permissible only if the reproduction is without alteration and is accompanied by associated warranties, conditions, limitations and notices. Reproduction of this information with alteration is an unfair and deceptive business practice. PLE is not responsible or liable for such altered documents.

Resale of PLE products or services with statements different from or beyond the parameters stated by PLE for that product or service voids all express and implied warranties for the associated PLE product or service and is an unfair or deceptive business practice. PLE is not responsible for any such statements.

Contacting Pletronics Inc.

Pletronics, Inc.
19013 36th Ave. West
Lynnwood, WA 98036-5761
U.S.A.

Tel: 425.776.1880
Fax: 425.776.2760
email: ple-sales@pletronics.com
URL: www.pletronics.com