



LP490068-3.6864M Low Profile Crystal

June 2017

- The Pletronics' LP49 Series is a low profile thru-hole crystal
- Bulk packaging
- Insulator
- 3.6864 MHz
- HC-49/US
- AT Cut Fundamental Mode Crystal
LP49 0.140 (3.56mm) high

Pletronics Inc. certifies this device is in accordance with the RoHS (2011/65/EC) and WEEE (2002/96/EC) directives.

Pletronics Inc. guarantees the device does not contain the following:

Cadmium, Hexavalent Chromium, Lead (<1000 ppm), Mercury, PBB's, PBDE's

Weight of the Device: 0.62 grams

Moisture Sensitivity Level: 1 As defined in J-STD-020C

Second Level Interconnect code: e1, e2 or e3

Electrical Specification with insulator:

Item	Min	Typical	Max	Unit	Condition
Frequency	-	3.6864	-	MHz	AT cut
Calibration Frequency Tolerance	-50	-	+50	ppm	at +25°C ± 3°C
Frequency Stability over OTR	-50	-	+50	ppm	
Load Capacitance	-	20	-	pF	
Equivalent Series Resistance (ESR)	-	-	130	Ohms	Fundamental Mode
Drive Level	-	-	100	µW	use 10 µW for testing
Shunt Capacitance (C0)	-	-	7	pF	Pin to Pin capacitance
Operating Temperature Range	-20	-	+70	°C	
Storage Temperature Range	-55	-	+125	°C	

Reliability: Environmental Compliance

Parameter	Condition
Mechanical Shock	MIL-STD-883 Method 2002, Condition B
Vibration	MIL-STD-883 Method 2007, Condition A
Solderability	MIL-STD-883 Method 2003
Thermal Shock	MIL-STD-883 Method 1011, Condition A

Package Labeling

Label is 1" x 2.6" (25.4mm x 66.7mm)
 Font is Courier New
 Bar code is 39-Full ASCII

Label is 1" x 2.6" (25.4mm x 66.7mm)
 Font is Arial

P/N:  LP490068-3.6864M Customer P/N:  12345678 Qty:  1000 D/C  6GX-WY MSL: 1
--

RoHS Compliant 2nd LvL Interconnect Category=e1 Max Safe Temp=260C for 10s 2X Max

RoHS Compliant 2nd LvL Interconnect Category=e3 Max Safe Temp=260C for 10s 2X Max

RoHS Compliant 2nd LvL Interconnect Category=e2 Max Safe Temp=260C for 10s 2X Max

Part Marking:

2G03686Pymdz

Legend:

- 2 = Model code for LP49
- G = 20 pF Capacitance load
- 03686 = 3.6864 MHz Frequency
- P = Pletronics
- ymd = Date of Manufacture (year, month and day)
- All other marking is internal factory codes

Specifications such as frequency tolerance and operating temperature range, etc. are not identified from the marking. External packaging labels and packing list will correctly identify the ordered Pletronics part number.

Codes for Date Code YMD

Code	3	4	5	6	7	8	9
Year	2013	2014	2015	2016	2017	2018	2019

Code	A	B	C	D	E	F	G	H	J	K	L	M
Month	JAN	FEB	MAR	APR	MAY	JUN	JUL	AUG	SEP	OCT	NOV	DEC

Code	1	2	3	4	5	6	7	8	9	A	B	C
Day	1	2	3	4	5	6	7	8	9	10	11	12
Code	D	E	F	G	H	J	K	L	M	N	P	R
Day	13	14	15	16	17	18	19	20	21	22	23	24
Code	T	U	V	W	X	Y	Z					
Day	25	26	27	28	29	30	31					

Mechanical:

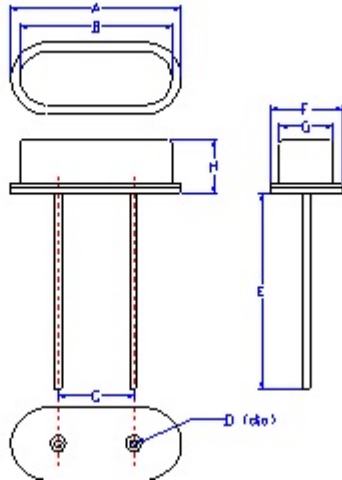

	Inches	mm
A	0.425 max	10.80 max
B	0.404	10.26
C	0.192	4.88
D	0.017 dia	0.43 dia
E	0.500 min	12.7 min
F	0.176 max	4.47 max
G	0.145	3.68
H	0.140 max	3.56 max

Contacts (3 types of lead plating used):

Matte Tin (Sn)

Tin over Copper (SnCu)

SAC (SnAgCu)

Not to Scale

¹ Typical dimensions

Layout and application information

- Trace lengths to the crystal should be kept as short as possible.
- The crystal connections are sensitive to noise.
- The package should be grounded for optimum performance.

AT Cut Crystal Frequency versus Temperature Typical Performance:

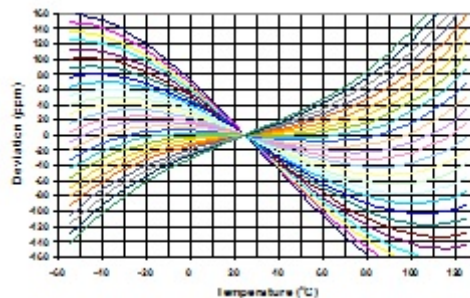

IMPORTANT NOTICE

Pletronics Incorporated (PLE) reserves the right to make corrections, improvements, modifications and other changes to this product at anytime. PLE reserves the right to discontinue any product or service without notice. Customers are responsible for obtaining the latest relevant information before placing orders and should verify that such information is current and complete. All products are sold subject to PLE's terms and conditions of sale supplied at the time of order acknowledgment.

PLE warrants performance of this product to the specifications applicable at the time of sale in accordance with PLE's limited warranty. Testing and other quality control techniques are used to the extent PLE deems necessary to support this warranty. Except where mandated by specific contractual documents, testing of all parameters of each product is not necessarily performed.

PLE assumes no liability for application assistance or customer product design. Customers are responsible for their products and applications using PLE components. To minimize the risks associated with the customer products and applications, customers should provide adequate design and operating safeguards.

PLE products are not designed, intended, authorized or warranted to be suitable for use in life support applications, weapons, weapons systems or space applications, devices or systems or other critical applications that may involve potential risks of death, personal injury or severe property or environmental damage. Inclusion of PLE products in such applications is understood to be fully at the risk of the customer. Use of PLE products in such applications requires the written approval of an appropriate PLE officer. Questions concerning potential risk applications should be directed to PLE.

PLE does not warrant or represent that any license, either express or implied, is granted under any PLE patent right, copyright, artwork or other intellectual property right relating to any combination, machine or process which PLE product or services are used. Information published by PLE regarding third-party products or services does not constitute a license from PLE to use such products or services or a warranty or endorsement thereof. Use of such information may require a license from a third party under the patents or other intellectual property of the third party, or a license from PLE under the patents or other intellectual property of PLE.

Reproduction of information in PLE data sheets or web site is permissible only if the reproduction is without alteration and is accompanied by associated warranties, conditions, limitations and notices. Reproduction of this information with alteration is an unfair and deceptive business practice. PLE is not responsible or liable for such altered documents.

Resale of PLE products or services with statements different from or beyond the parameters stated by PLE for that product or service voids all express and implied warranties for the associated PLE product or service and is an unfair or deceptive business practice. PLE is not responsible for any such statements.

Contacting Pletronics Inc.

Pletronics Inc.
19013 36th Ave. West
Lynnwood, WA 98036-5761 USA

Tel: 425-776-1880
Fax: 425-776-2760
E-mail: ple-sales@pletronics.com
URL: www.pletronics.com

Copyright © 2017 Pletronics Inc.